

ATTS

150Lm/w



LED High Mast Light

SLIM II

LED High Mast Light

Innovative C-buckle technology

Lens

Reflector

PCB

waterproof cover



Driver



Glass



Respirator

Waterproof nut

LED High Mast Light



Reflector



Innovative C-buckle technology



Waterproof cover



Die-casting



Respirator

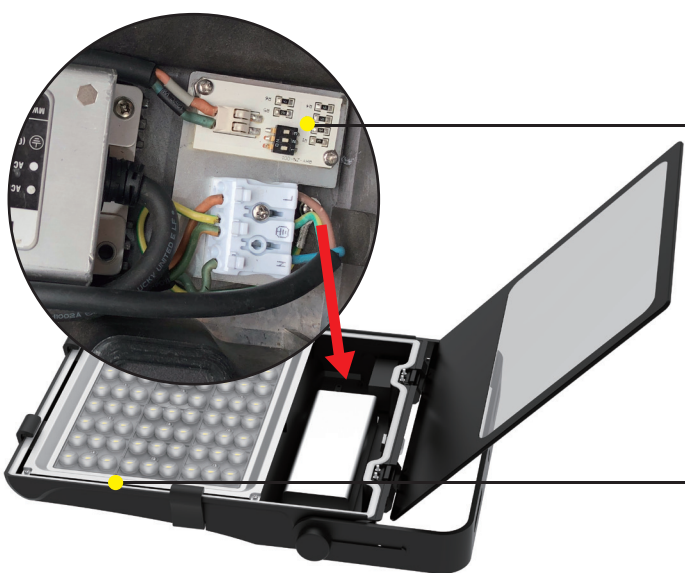

Wago Plug

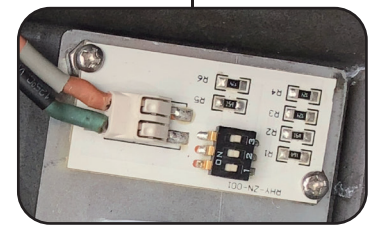
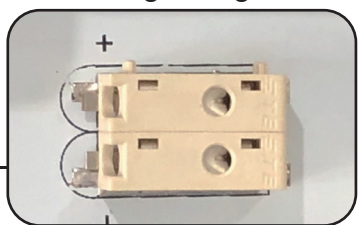

Dial switch

- power adjustable, save more storage cost for customers

Outline Drawing(MM)

100~300Watts

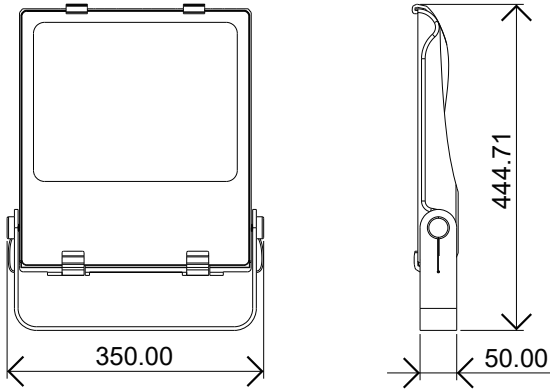

100W~150W

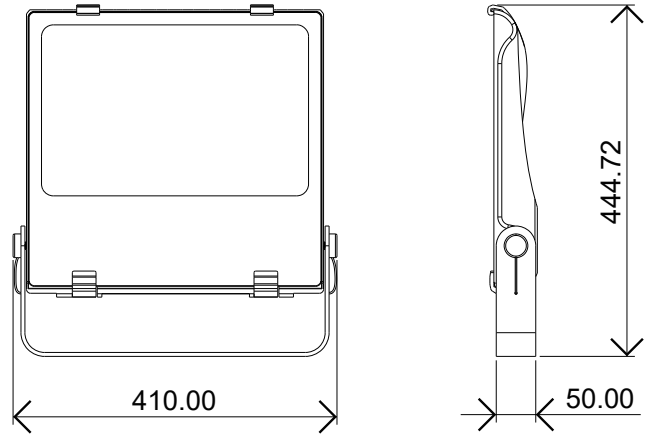

200W~240W

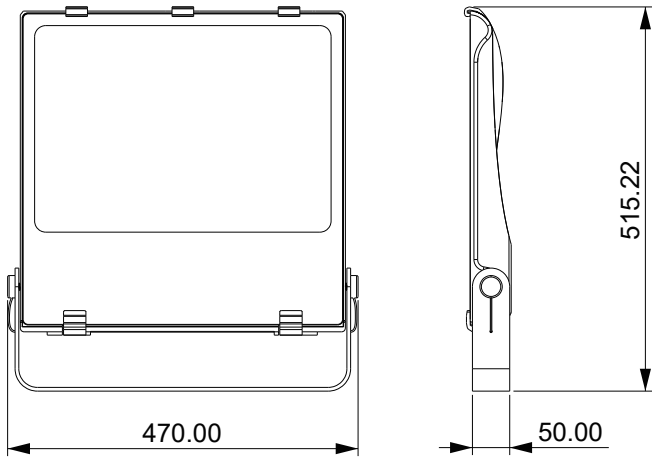

300W

Feature

- IP66, IK09
- 180° installation angle adjustable
- Die casting aluminum housing with good heat sink
- Innovative C-buckle technology, prevent glass off, free of screw fixing
- Multiple optical lens for different application

Light Distribution Curve

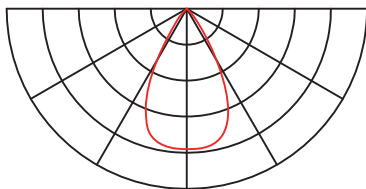

60°

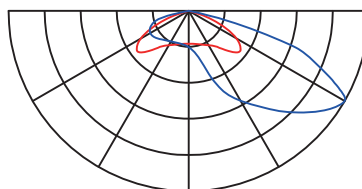

TYPE-IV

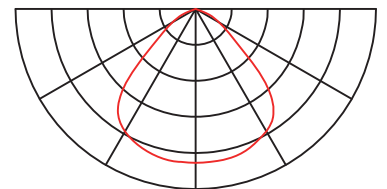

90°

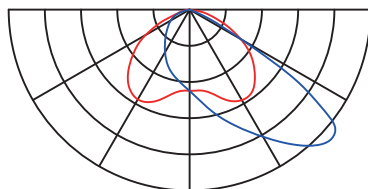

Asymmetric 50°

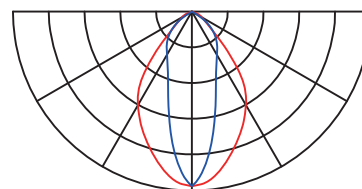

70°*30°

Specification

Input Voltage	AC100~277V/200~480V
LED Spec.	SMD5050
Operating Temperature	-30C°~50C°
Smart Control Options	1-10V/DALI/Photocell/Zigbee
Luminous Eff	150Lm/w
Structure	Die-Casting ADC12
Finish	Powder coated
Lens	Polycarbonate
Color	Black
Ra	>70

Applications

